



# MODEL 221R *OXYGEN DEFICIENCY MONITOR*



---

## *Operator Manual*

---

# MODEL 221R OPERATOR MANUAL

Special Message from Advanced Micro Instruments (AMI):

Thank you for purchasing this **MODEL 221R** for oxygen deficiency monitoring. This permanent mount analyzer is designed to alert you and your employees to unsafe oxygen levels within an enclosed area. The audible alarm and relay outputs activate when an oxygen-depleted or oxygen-rich environment is detected. The unit's special design provides exceptional protection while eliminating the frustrations of having to deal with false alarms.

Note: Read this manual carefully prior to installation.

## TABLE OF CONTENTS

ANALYZER OVERVIEW	2
METHOD OF MEASUREMENT:	3
SAFETY, WARNINGS & CAUTIONS	4
ANALYZER INSTALLATION	5
ANALYZER OPERATION	13
ANALYZER CALIBRATION	15
SENSOR REPLACEMENT	19
TROUBLESHOOTING/SERVICE	19
ANALYZER ACCESSORIES	20
SPECIFICATIONS	21
AMI® WARRANTY	23
LIMITED WARRANTY/DISCLAIMER	23
LIMITATION OF LIABILITY	23
LIMITATION OF REMEDIES	23

# ANALYZER OVERVIEW

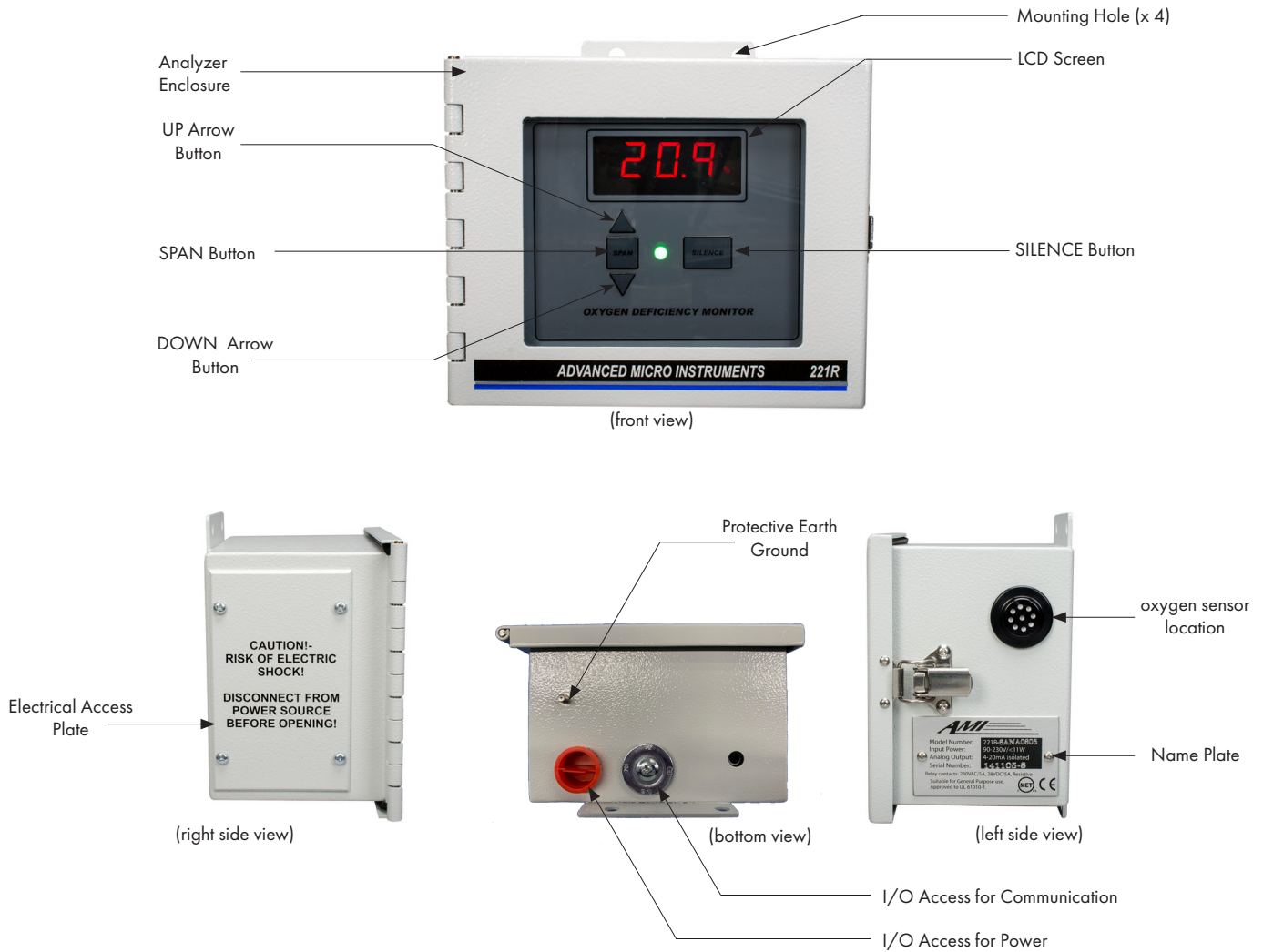

## AVAILABLE CONFIGURATIONS

(must be specified at time of purchase)

**BASE UNIT ONLY**  
**(PART # 6ANA0600)**



**UNIT WITH POWER CORD**  
**(PART # 6ANA0605)**



**UNIT WITH REMOTE PROBE**  
**(PART # 6ANA0615)**



**UNIT WITH POWER CORD & REMOTE PROBE**  
**(PART # 6ANA0610)**



# METHOD OF MEASUREMENT: ZIRCONIUM OXIDE SENSORS

The **MODEL 221R** utilizes zirconium oxide sensors, which provides reliable, accurate percent oxygen measurements for a general purpose environment.

- These sensors have up to a 10-year product life. This eliminates the need to replace sensors every 6 months and the need to perform monthly calibrations, which drastically lowers maintenance costs.



# SAFETY, WARNINGS & CAUTIONS



## WARNING

Make sure no hazardous gas is present in the area before and during installation.

Violation of the National Electrical Code requirements (especially Article 500 that deals with hazardous areas) may cause a fire or explosion with the potential for serious injury or loss of life.



## WARNING

You must follow all installation requirements and environmental conditions to avoid protection impairment.

Do not mount the **MODEL 221R** analyzer in a hazardous area, where explosive gases may be present. The zirconium oxide sensor will ignite flammable gas mixtures.

A switch or circuit-breaker shall be included in the building installation for the AC power connection. The circuit breaker should be as close as possible to the unit and within easy reach for the operator. The circuit breaker should be marked as the disconnecting device for the analyzer.



## CAUTION

*You must follow the National Electrical Code (NEC) in your installation.*

*A supplied IEC power cord must be used if the unit is not to be hard wired. You must follow the National Electrical Code (NEC) in your installation.*

*If the unit is hard-wired, the AC wire connecting to the circuit board is made using the three pin Phoenix combination connector located behind a protective white metal shield.*

*The Protective Earth Ground Lug on the unit must be connected to the High-Quality Protective Earth Ground using a 16-gauge wire.*



# ANALYZER INSTALLATION

## Key Points:

- It is highly recommended that the Oxygen Deficiency Monitor be installed close to the potential leak source, most likely to be the cause of oxygen depletion
- The zirconium oxide sensor is located on the right side of the box. Make sure that this side is properly orientated to the potential source of oxygen depletion.
- The Oxygen Deficiency Monitor is designed to be mounted in a general-purpose area. Do not install it in a hazardous area containing flammable gases.
- It is recommended that you purchase the optional power cord with your unit. This will allow you to unplug and move the unit to an area with fresh ambient air when scheduled calibration needs to be performed. *Note: The unit is also designed to be hard-wired if that is your preference*
- Analyzer must be connected to a solid ground for the highest level of RFI protection and safety.
- Use 18 to 16 gauge wire for your electrical connections.



### CAUTION:

The **MODEL 221R** is designed for operation between 41 °F to 104 °F.



### CAUTION:

The **MODEL 221R** is designed for monitoring of atmospheric air. Use of the unit to monitor process gas will shorten the life of the zirconium oxide sensor and void the warranty.



### CAUTION:

#### Ventilation Requirements:

Install the unit near the area where the oxygen levels need to be monitored. Leave a gap of at least 12" around all faces of the unit's case. (Note: This gap does not include the unit's backside).

## ANALYZER ENGINEERING DRAWING

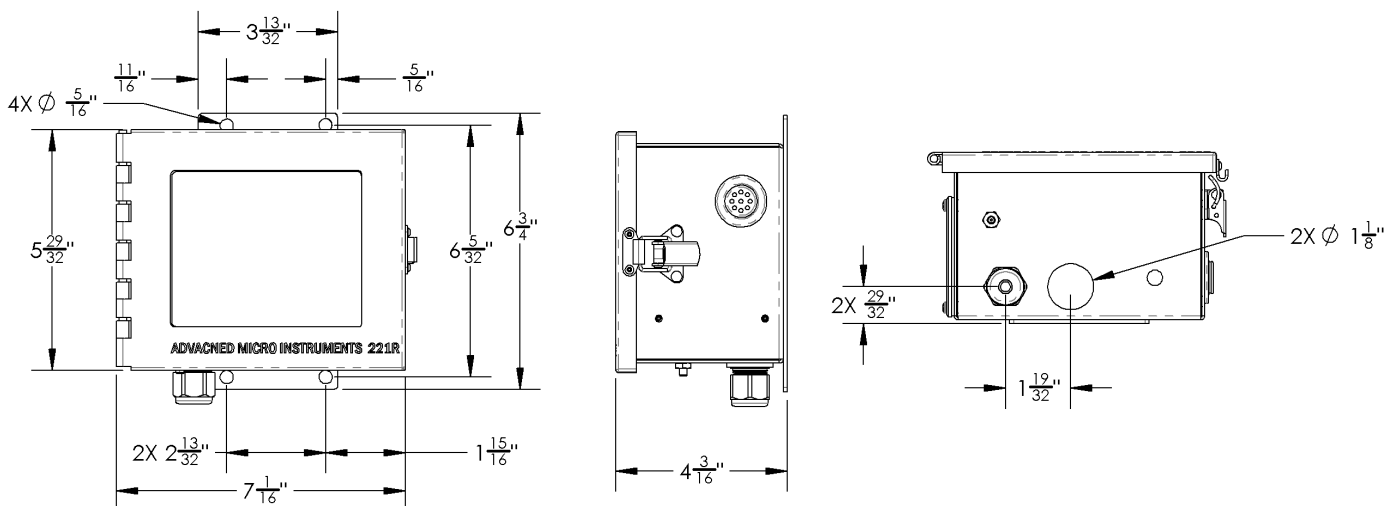

## OPTION 1: INSTALLATION WITH THE POWER CORD



1. Place the Oxygen Deficiency Monitor at a desired location. It is recommended to position the unit at eye-level. Make sure the location is no more than 6 ft from an electrical outlet if the unit has the standard 6-ft cord.
2. Secure the unit to the wall using the 4 mounting holes.



3. Plug the Power Cord into an AC Power Outlet (The length of the power cord is 6 ft).
- 

## OPTION 2: HARD WIRING

1. Turn off the mains power.



2. Place the Oxygen Deficiency Monitor at a desired location. It is recommended to position the unit at eye-level.
3. Secure the unit to the wall using the 4 mounting holes.

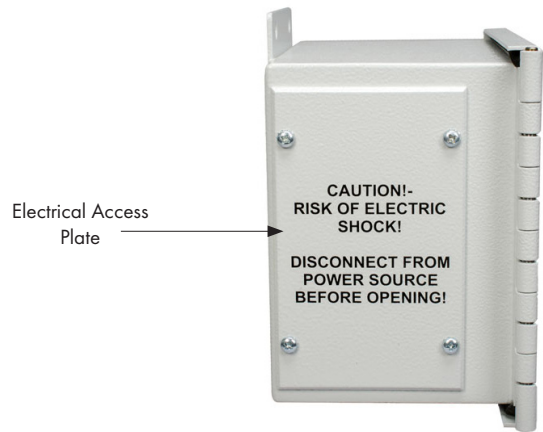

4. Remove the Electrical Access Plate on the **MODEL 221R** to reveal the electrical connections.



5. Remove the Access Plug on the bottom side of the **MODEL 221R**.



6. Install a cable gland in the I/O Access for Power. The cable gland should be rated to NEMA 4X (IP65) at the minimum. A cable gland can be acquired from AMI as a separate purchase (Part # 1CON02).



7. Feed cable through the cable gland, which fits Cord OD of 0.24" to 0.47".



8. Remove the 3-terminal green connector from the terminal strip for easier wiring.
9. Make the following electrical connections to the proper positions on the Phoenix connector.
  - Connect the fused line side of a 90 —240 VAC power source to the H terminal
  - Connect the neutral from the power source to the N terminal
  - Connect the shield ground to a good earth ground or equivalent.

**IMPORTANT:** When attaching wiring to the green terminal connectors, use either solid wire or stranded wire with wire ferrule(s) attached. Verify no loose strands are visible after installation of wire ferrule(s).



10. Re-install the 3-terminal green connector firmly back in its place in the terminal strip.

## HARD WIRING FOR RS485 COMMUNICATIONS, 4-20mA, AND ALARM RELAYS

Follow the next several steps to wire RS485 Communications, 4-20 mA or Alarm Relays. If you do not wish to include any of these in your installation, skip this section and proceed to Step 14.

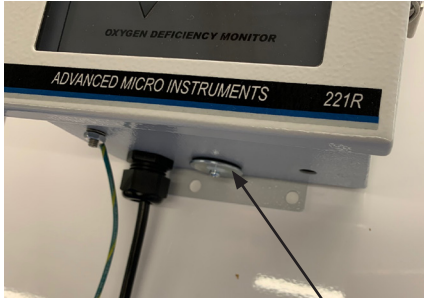

Metal Hole Plug

11. Remove the Metal Hole Plug.



12. Install a cable gland to the I/O Access for Communication. The cable gland should be rated to NEMA 4X (IP65) at the minimum. A cable gland can be acquired from AMI as a separate purchase (Part # 1CON02).



13. Feed cable through the cable gland.

14. Remove the appropriate 3-terminal green connector that corresponds to your target wiring.
15. Make the following electrical connections to the proper positions on a Phoenix connector.
  - Connect the fused line side of a 90 –240 VAC power source to the H terminal
  - Connect the neutral from the power source to the N terminal
  - Connect the shield ground to a good earth ground or equivalent.



16. Connect the Phoenix connector to the appropriate Interface Group.

**LIST OF INTERFACE GROUP & CORRESPONDING CONNECTION**

INTERFACE GROUP	CONNECTION
1st Interface Group	RS485 Communications
2nd Interface Group	4–20mA Analog Output
3rd Interface Group	Alarm One Relays
4th Interface Group	Alarm Two Relays

Note: The RS485 cable, which has a length of ~ 6 ft (1.8 m), must be purchased separately from AMI (Part # 3DON01).

**OUTPUT CONNECTIONS**

RS 485	A B ⊕
ISO 4 - 20 mA	- + ⊕
Alarm 1	NO C NC
Alarm 2	NO C NC
~ AC Power	⊕ H N

To complete wiring for another connection, repeat Steps 12 & 13 and select a different connection to install the Phoenix connector.



17. Put the Electrical Access Plate back in place and secure.



18. Connect the shield ground to a good earth ground or equivalent.
19. Turn on the mains power.

## INSTALLATION WITH REMOTE PROBE (OPTIONAL)

### PROBE & BRACKET ENGINEERING DRAWING

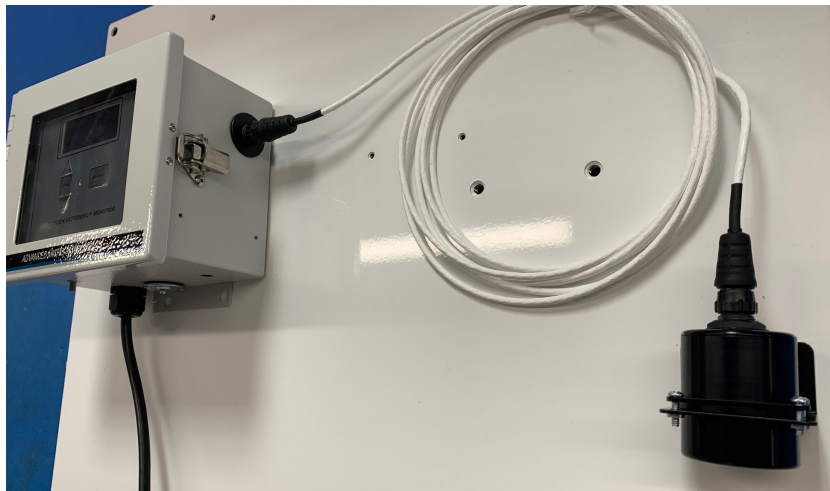
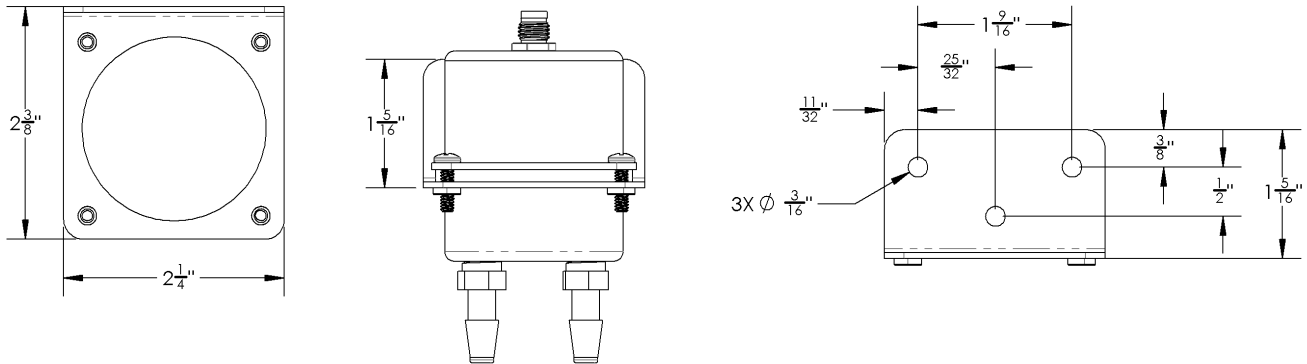

Customers that ordered the **MODEL 221R** with Remote Probe can mount the Probe using the included bracket as shown above.

Note: The probe includes a 12-ft cable, but customers can extend to a maximum length of 300 ft by following these steps.

- Cut the 12-ft cable into two segments, where there is a 1-ft working minimum at each end.

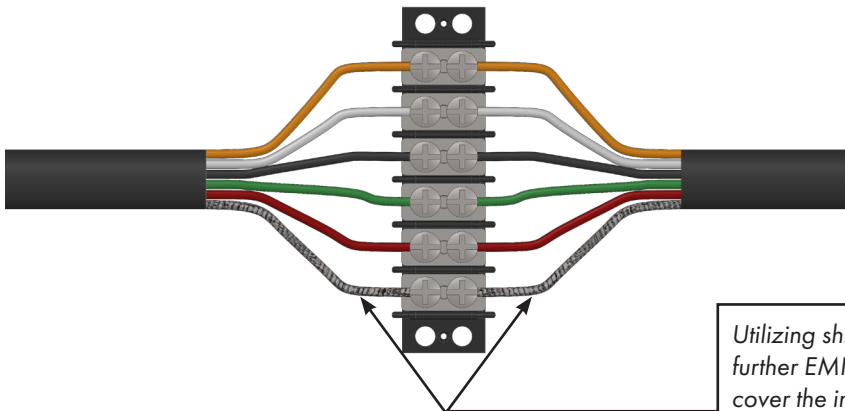

#### CAUTION:

The color of the ends **MUST MATCH**. Swapping any wire may cause the Analyzer to not function properly or damage to it.

Utilizing shield from cable, twist and connect to the barrier. For further EMI shielding, cover the barrier with insulation. Then, cover the insulation with an EMI shield, such as aluminum foil, connected to the cable shield terminal on the barrier directly on a terminal strip as shown in the above image.

- In between the cut cable, splice each end of the additional length of cord to a 16–22 AWG shielded 5-conductor. Wire each colored wire to its matching equivalent directly on a terminal strip as shown in the above image.

# ANALYZER OPERATION

## Front Panel Interface



## What are the Alarm Conditions and the LED Warnings?

INDICATION	LED COLOR	AUDIBLE ALARM	RELAYS
Below 19.5% Oxygen DANGER Level	Solid Red Warning Light	95 dB ON	Relay 1 de-energized, Relay 2 de-energized
Above 23.5% Oxygen ENRICHED Level	Solid Red Warning Light	95 dB ON	Relay 1 de-energized, Relay 2 de-energized
Below 20.0% Oxygen CAUTION Level	Solid Yellow Caution Light	OFF	Relay 1 de-energized, Relay 2 energized
Safe Oxygen Levels Normal Level	Solid Green Light	OFF	Relay 1 energized, Relay 2 energized

Note: The Common Contact (C) and Normally-Close Contact (NC) will close whenever an alarm is triggered.

If the unit detects oxygen levels less than 20%, the LED on the front panel will change from green to yellow.

If it detects oxygen level below 19.5% (OSHA standard), the LED will change to red, and the audible alarm will sound to alert personnel to leave the room. The audible alarm is rated at 95dB.

If oxygen levels exceed 23.5%, the audible alarm will sound.



### WARNING:

If the alarm is triggered for 19.5% oxygen levels, LEAVE THE AREA IMMEDIATELY!

POWER STATUS	LED COLOR	ACTIVITY
Unit Warming-up	Solid Blue Light	Alarms are disabled.
Lost of AC Power, Back-up Battery Power Running	Flashing Red Warning Light	No audible alarm, and Relay 1 and Relay 2 perform as normal.
After ~45 min of Back-up Battery Power Use	Flashing Red Warning Light	Audible Alarms Trigger, no LCD Reading, Relay 1 and Relay 2 de-energize.

## What happens when there is a blackout or loss of AC power to the unit?

The **MODEL 221R** has a battery back-up. If the AC power fails, the internal batteries will keep the unit operational for about 1 hour. During this time, the LED backlight on the LCD panel will flash, and the status LED will turn red and flash. After 45 min of running on back-up battery power, the audible alarm will trigger. And after about 1 hour of total time running on back-up battery power, the batteries will start to die, and the LCD back light will turn off though the LED will continue to flash.

## How do I silence the alarm?



Press the SILENCE button on the front panel. The Monitor will remain silent for the amount of time set in the System. The default setting is 1 minute.

# ANALYZER CALIBRATION

Note: The **MODEL 221R** Oxygen Deficiency Monitor has been calibrated at the factory at an atmosphere at sea level and is ready for use. It should be re-calibrated again if the new unit is installed at a different elevation than at sea level.

AMI recommends to calibrate the unit once a year.

There are 2 methods for calibration:

- Calibration with Air
- or
- Calibration with a Span Gas

## CALIBRATION WITH AIR

For this option, you will need to remove the Oxygen Deficiency Monitor from where it is currently installed and take it to a location where there is fresh ambient air. This will ensure that no contaminant will interfere with the calibration.

Note: Once the Monitor is disconnected from the AC power source, its battery will continue to supply 1 hour of back-up power.

1. Once in an area with fresh ambient air, the oxygen level reading should stabilize rather quickly.



2. Verify that the Oxygen Deficiency Monitor is reading 20.9%. If not, press the SPAN button and, within 3 seconds, use the UP or DOWN arrow buttons to adjust the LCD reading to 20.9%.

Note: Unlike AMI's other Analyzers, the display on this unit WILL NOT blink when the SPAN button is pressed.

3. Return the **MODEL 221R** back to its location, reinstall it and reconnect it to power.

## CALIBRATION WITH A SPAN GAS

We encourage you to view our calibration video at [www.amio2.com](http://www.amio2.com) before starting.

### REQUIRED COMPONENTS:

- Certified oxygen span gas with a nitrogen background  
  
Note: AMI recommends a percent oxygen span gas between 10 to 20% with the balance being nitrogen.
- Calibration adapter - Part Number 4BLK41 (sold separately by AMI)
- Stainless-steel or brass body pressure-reducing regulator that is outfitted with inlet/outlet pressure gauges, with the outlet port being a compression fitting for ¼" tube (note: the regulator must have a diaphragm, made from one of the following materials – best option: stainless steel, secondary option: aluminum, or tertiary option: brass)
- Tank wrench

### IMPORTANT:

- The Block and Bleed procedure is required only when a regulator has been connected to a gas cylinder for the first time or has not been used for an extended period of time
- The Block and Bleed procedure will clear any trapped oxygen from the regulator and insure an accurate calibration.

### 'BLOCK AND BLEED' STEPS

1. Connect a pressure reducing regulator to the Span Gas Tank.

Note: It is essential that the regulator has a stainless-steel diaphragm. Failure to do so will invalidate the calibration.

2. After the regulator has been attached to the Span Gas Tank and properly tightened, 'Block and Bleed' the High Pressure side of the Span Gas Regulator following this procedure:

Quickly open the valve of the Span Gas Tank approximately ~½ turn. Confirm the inlet pressure gauge responds to 'full tank pressure'. Then, quickly close the valve of the Span Gas Tank.

Loosen the regulator nut that connects the regulator to the Span Gas Tank approximately ¼ turn using a wrench until the inlet pressure gauge drops to zero, and then quickly tighten the regulator nut to the Span Gas Tank.

Repeat the above procedure 7 times.



Calibration  
Adapter

3. Connect the Calibration Adapter to the Analyzer and then connect non-diffusive flexible tubing from the regulator to the Calibration Adapter.

Note: You CANNOT use Teflon® or another plastic tubing for this step as it would allow oxygen from the air to diffuse into the Span Gas Stream and invalidate your calibration.

4. Now, 'Block and Bleed' the Low Pressure side of the Regulator:

Connect the flexible tubing to the Calibrator Adapter of the Analyzer so gas can escape during the 'Block & Bleed' process.

Open the valve of the Span Gas Tank approximately ½ turn. Confirm the high-pressure and low pressure gauges respond. Then, quickly close the valve of the Span Gas Tank.

Note: The gas will escape at the Span Gas Inlet Port since it is not fully sealed connection.

Repeat this procedure 7 times - but tighten the gas fitting at the Span Gas Inlet Port for the last 'Block & Bleed'

## CALIBRATION STEPS

1. Connect the Calibration Adapter to the **MODEL 221R**.
2. Open the valve of the Span Gas Tank and adjust the regulator pressure to approximately 20 psig.
3. Allow a brief moment for the measurement reading to stabilize.
4. If the Span Gas used is outside the alarm settings and causes an alarm to trigger, press the SILENCE Button to quiet the alarm. This will last for 60 seconds (by default). If it takes longer than 60 seconds to complete the calibration, the SILENCE Button will need to be pushed again to quiet the alarm for another 60 seconds.

5. Span the Analyzer to the value of the oxygen, specified on the Span Gas Tank, by doing the following:

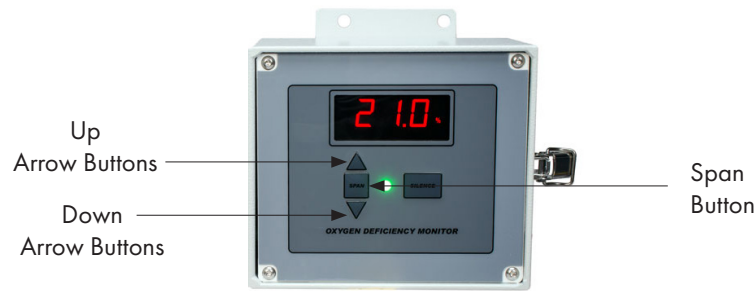

Press the SPAN Button and release, and, within 3 seconds, use the UP or DOWN arrow buttons to adjust the LCD reading to the value stated on your calibration gas cylinder.

The calibration is now completed.

---

## How do I view the current calibration Span Factor?



Press the UP Arrow Button.

### **IMPORTANT:**

The SPAN FACTOR is an indication of sensor life. The span factor is accurate only after an accurate calibration has been completed.

The SPAN FACTOR of a new oxygen sensor is in the range of 400 to 600.

After each calibration, the SPAN FACTOR will increase slightly. When the SPAN FACTOR reaches around 980, the sensor is nearing the end of its useful life. Contact AMI to return your unit for sensor replacement.

---

## What is the actual oxygen percentage range associated with the 4 – 20 mA output?

The range is as follows:

- 4 mA: 0.0% oxygen
- 20 mA: 25.0% oxygen

## How do I view the Last Calibration Date?



Press the DOWN Arrow Button to view the last date in 'month.year' (mm.yy) format.

---

## SENSOR REPLACEMENT



The **MODEL 221R** is shipped from our factory with the zirconium oxide sensor already installed inside the Oxygen Deficiency Monitor.

The zirconium oxide sensor has a product life up to 10 years.

To replace the sensor near the end of its product life, contact AMI to make arrangements. The sensor can only be replaced on the **MODEL 221R** at our factory.

---

## TROUBLESHOOTING/SERVICE

The **MODEL 221R** has no serviceable parts inside. If you encounter an issue with your unit, contact AMI for support and to obtain a Return Material Authorization (RMA).

---

# ANALYZER ACCESSORIES

There are several accessories available for purchase for the **MODEL 221R**.

Accessories	Part Number
Calibration Adapter	4BLK41
Cable Gland for I/O Access for Power, for Cord OD 0.24" to 0.47"	1CON02
RS485 cable with length ~ 6 ft (1.8 m)	3DON01

---

# SPECIFICATIONS

## USAGE

Both indoor and outdoor use

Max Altitude \_\_\_\_\_ 15,000 ft

Relative Humidity \_\_\_\_\_ Maximum relative humidity is 80% for temperatures up to 88°F,  
This maximum relative humidity decreases linearly to 50% relative humidity at 104°F.

Ingress Protection \_\_\_\_\_ Designed to meet IP65

Pollution degree: 2 (Only non-conductive pollution occurs except that occasionally a temporary conductivity caused by condensation is to be expected).

## PHYSICAL

Dimensions \_\_\_\_\_ 7.0"W x 5.7"H x 4.5"D (18 cm x 15 cm x 11 cm)  
Weather-tight 4X package

Weight \_\_\_\_\_ 4.0 lbs

Digital Display \_\_\_\_\_ 4-digit LCD (reads full scale from 0.0% to 25.0%)

Mounting \_\_\_\_\_ Wall mount

Gas Connections \_\_\_\_\_ Diffusion screen. No pump, sample tubing or fittings required

## TECHNOLOGY

Method of Measurement \_\_\_\_\_ Zirconium Oxide Sensor (up to 10-year life expectancy)

Key Technologies \_\_\_\_\_ **Command Center Electronics Platform™**  
(with Datalogger, Security Lockout Settings, Alarm Settings, Brown-out History, Power-up History, Modbus RS485 and Modbus TCP/IP)

## PERFORMANCE

Low Minimum Detection Threshold \_\_\_\_\_ 0.05% of oxygen

Response Time \_\_\_\_\_ 90% full scale response times for specified range: <12 sec (0.0 – 25.0%)

Repeatability \_\_\_\_\_ ±0.1% of range or ±0.1% of oxygen, whichever is greater

Diurnal Temperature Specification \_\_\_\_\_ < ±1 % of scale over temperature range

Data Collection Capacity \_\_\_\_\_ 10 days of data recording @1 datapoint per minute

Protection \_\_\_\_\_ RFI-protected

## OPERATION

Measurement Range \_\_\_\_\_ 0.0% – 25.0% of oxygen

Operating Temperature Range \_\_\_\_\_ 14°F to 122°F (-10°C to 50°C)

Isolated Analog Output Signals \_\_\_\_\_ 4–20 mA

Status LED \_\_\_\_\_ Indicates Power, Safe Operation, Alarm Conditions and Loss of AC Power

## ALARMS

Number of Alarms \_\_\_\_\_ 2 Oxygen Concentration Alarms with Dry Contacts (3A @24 VDC/115VAC)  
Preset for the OSHA Standard of 19.5%

95dBA Danger Alarms: Preset for 19.5% and 23.5%

Alarm Silence/Bypass \_\_\_\_\_ 60 seconds (default)

## AREA CLASSIFICATION

Area Classification \_\_\_\_\_ Approved to meet General Purpose UL 61010-1 Standard  
CE Marked

## OPTIONS

Probe \_\_\_\_\_ Optional Remote Oxygen Sensing Probe  
(can be located up to 300 ft away from the control unit)

## POWER

Requirements \_\_\_\_\_ 90-240VAC 50/60Hz (11W)  
Mains supply voltage fluctuations up to +/-10% of the nominal voltage

Battery back-up \_\_\_\_\_ 1 hour

# AMI<sup>®</sup> WARRANTY

## LIMITED WARRANTY/DISCLAIMER

The warranty period is **TWO YEARS** for the Analyzer. Any failure of material or workmanship will be repaired free of charge for that specified period from the original purchase (shipping date) of the instrument. AMI will also pay for 1-way ground shipment back to the customer.

The warranty period for the electrochemical oxygen sensor is 6 months.

The warranty period for the electrochemical H<sub>2</sub>S sensor is 6 months.

Any indication of abuse or tampering of the instrument will void the warranty.

### Receiving the Analyzer

When you receive the instrument, check the package for evidence of damage and if any is found contact the shipper. Although every effort has been made to assure that the Analyzer meets all performance specifications, AMI takes no responsibility for any losses incurred by reason of the failure of this analyzer or associated components. AMI's obligation is expressly limited to the Analyzer itself.

EXCEPT FOR THE FOREGOING LIMITED WARRANTY, AMI MAKES NO WARRANTIES, EXPRESS, IMPLIED OR STATUTORY, AS TO THE NON-INFRINGEMENT OF THIRD-PARTY RIGHTS, MERCHANTABILITY, OR FITNESS FOR A PARTICULAR PURPOSE. IF APPLICABLE LAW REQUIRES ANY WARRANTIES WITH RESPECT TO THE SYSTEM, ALL SUCH WARRANTIES ARE LIMITED IN DURATION TO TWO (2) YEARS FROM THE DATE OF DELIVERY.

## LIMITATION OF LIABILITY

IN NO EVENT WILL AMI BE LIABLE TO YOU FOR ANY SPECIAL DAMAGES, INCLUDING ANY LOST PROFITS, LOST SAVINGS, OR OTHER INCIDENTAL OR CONSEQUENTIAL DAMAGES, EVEN IF THE COMPANY HAS BEEN ADVISED OF THE POSSIBILITY OF SUCH DAMAGES, OR FOR ANY CLAIM BY ANY OTHER PARTY.

## LIMITATION OF REMEDIES

AMI's entire liability and your exclusive remedy under the Limited Warranty (see above) shall be the replacement of any Analyzer that is returned to the Company and does not meet the Company's Limited Warranty.

---

**PAGE INTENTIONALLY LEFT BLANK**



Instrument Expert  
Original factory packaging  
[www.keruiyiqi.cn](http://www.keruiyiqi.cn)



HIGH PERFORMANCE

RELIABILITY

INTUITIVE DESIGN

[www.amio2.com](http://www.amio2.com)

Tel 714.848.5533  
Fax 714.848.4545  
Email [sales@amio2.com](mailto:sales@amio2.com)

OM-300-006 Rev F  
02/22/2023

© Advanced Micro Instruments, Inc.

**ADDRESS:**

Advanced Micro Instruments, Inc.  
225 Paularino Avenue  
Costa Mesa, CA 92626

